

We reserve all rights to this drawing, to any patents or patent registrations related hereto, and to the duplication, retransmission by third parties and misc. use. Any use of this drawing is not permitted without the written consent of STABILUS.

Intended for internal use and customer

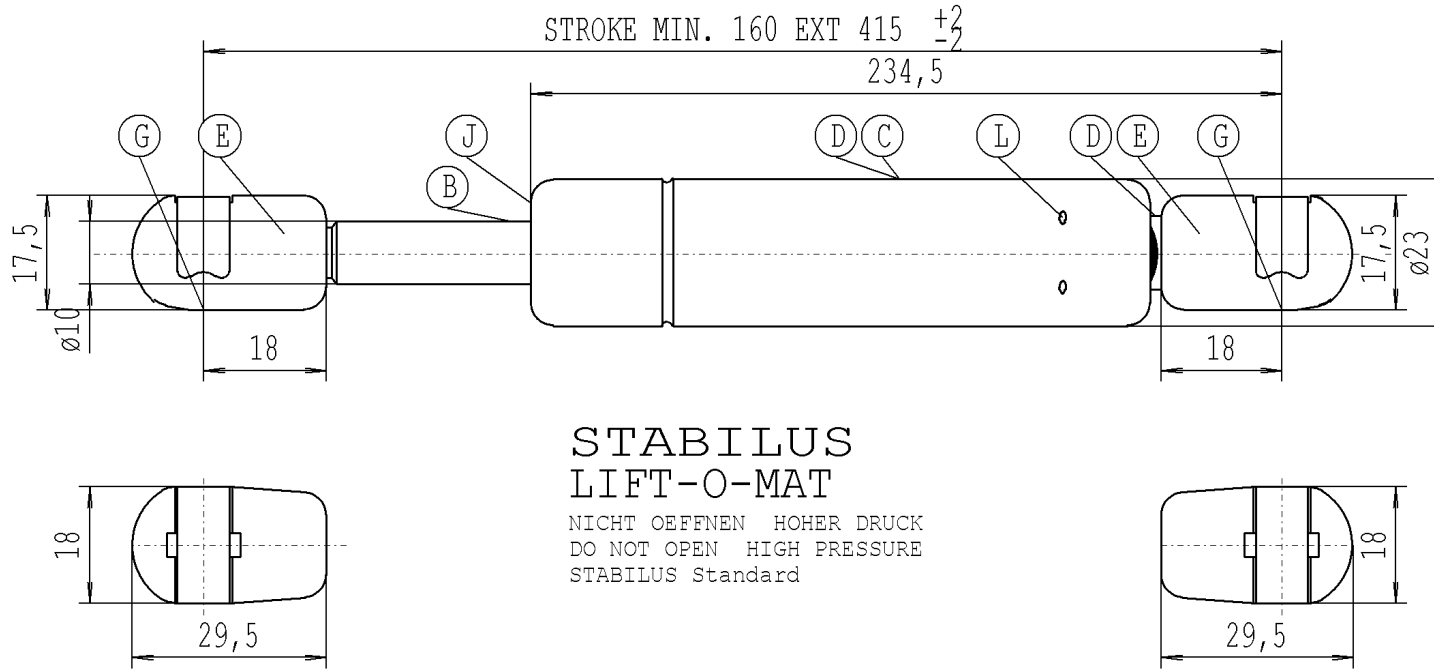

- the Gas Spring must not be mechanically modified or damaged.
- The warning label must not be removed or obscured.
- Extension speed VS2=0,1-0,3 (m/s)
- compression and extension forces measured acc. to STAB-Spec. 10009033
- Extension speed measured according to STAB-Spec. 10005451
- Spring test with piston rod downwards
- Line up connections permissible deviation ± 5 DEG
- Protect piston rod from dirt, paint and damage
- Disposal acc. to STAB-Spec.10009375
- Drawing not true-to-scale
- Observe installation instructions according to STAB-Spec. 10005593
- Ball socket to suit ball stud DIN 71803 ø10
- Disassemble ball-stud to STAB-Spec.10006399
- Permissible operating temperature range -30°C to +80°C
- Installation: With piston rod down to ensure best possible durability performance of the gas spring.
- Component testing gas spring acc. STAB-Spec. 10010035

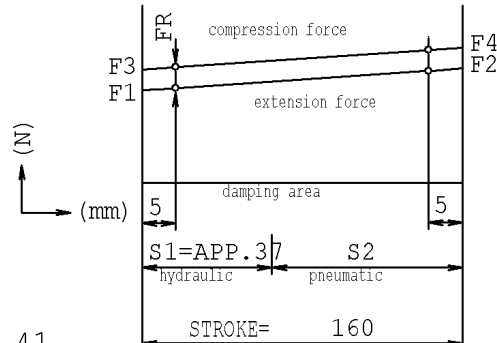

$X = F2 / F1 = 1,41$
 $FR_{max} = F3 - F1$

- B Nislid black
- C print white
- D black painted
- E Releasing torque min. 3.0 Nm
- G greased
- J border flange oiled
- L dinks permissible

Unregistered Copy
Print-out is not subject to the modification service

CHANGE	NEW	SERIE
	OLD	VERSUCH
	CHG.NO.	512837
	NAME	02.02.01 SCHNASS
	NO.	1

STABILUS

Modifications in favour of technical process reserved

Forces (statically measured)

F1 (N)	F4 max (N)	FR max (N)
extension force	compression force	friction
1250±63	2090	80

DIMENSIONS WITH-OUT TOLERANCE

LIFT-O-MAT

+/-1

03 01 1019 20 160

DRAWING		CHECKED	
DATE	04.05.2000	NAME	R.Schoemehl
Document No.		10013836	

6938NW

E